

9 SECTION - TEMPORARY HORDING
A6.0 SCALE: 1:5 CADD FILE: 0000A0-0

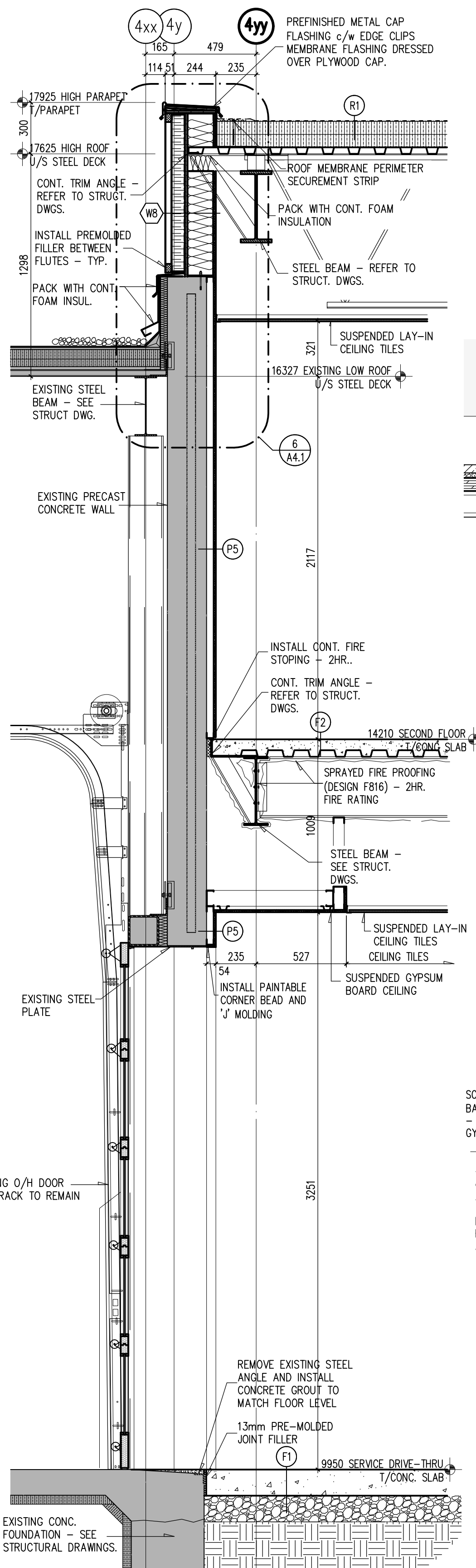

8 SECTION - EXISTING O/H DOOR
A6.0 SCALE: 1:20 CADD FILE: 0000A0-0

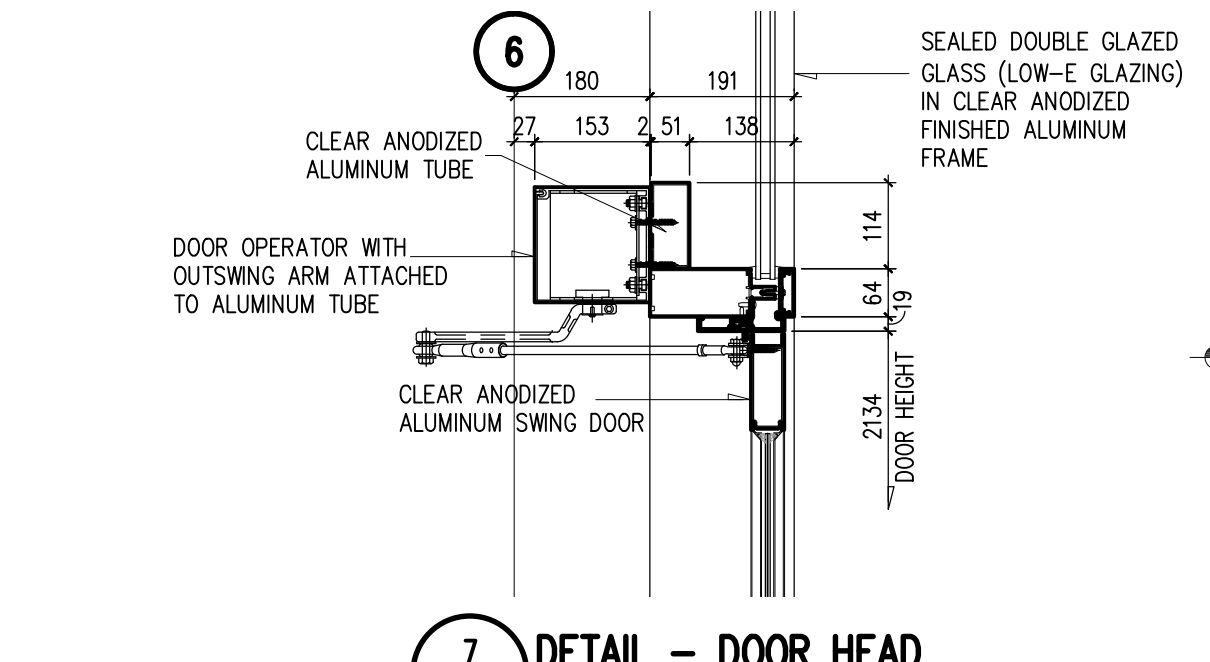

7 DETAIL - DOOR HEAD
A6.0 SCALE: 1:10 CADD FILE: 0000A0-0

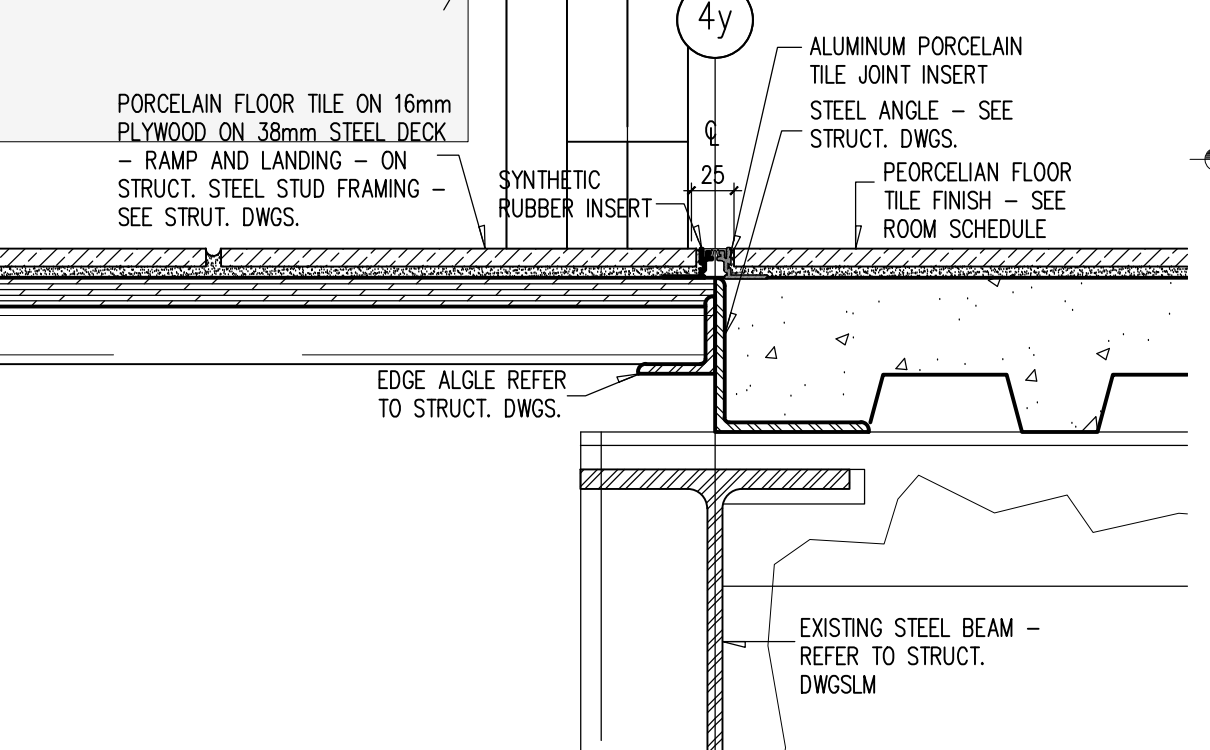

4 DETAIL - SECOND FLOOR OFFICE RAMP CONNECTION
A6.0 SCALE: 1:5 CADD FILE: 0000A0-0

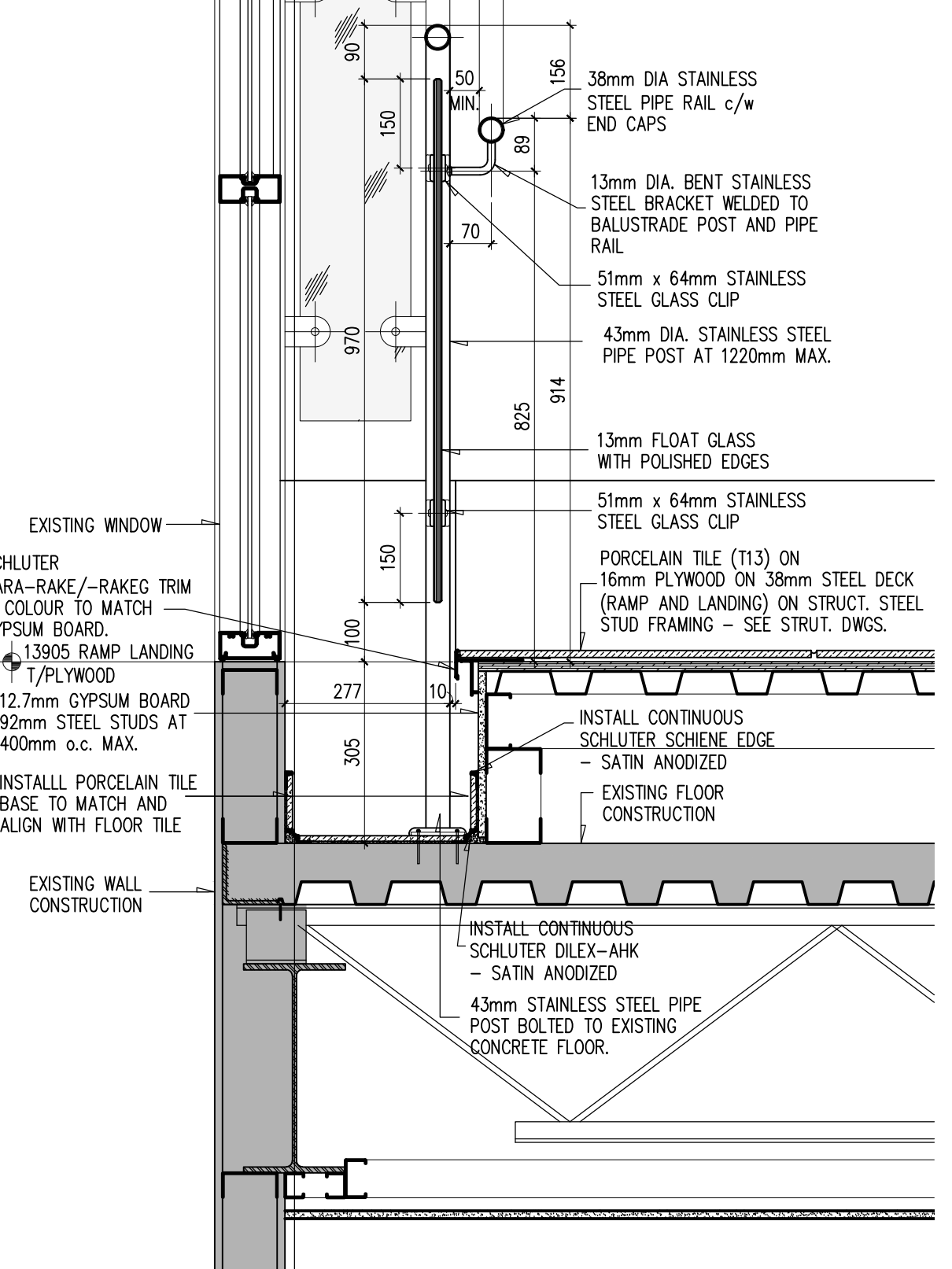

3 DETAIL - SECOND FLOOR OFFICE RAMP
A6.0 SCALE: 1:10 CADD FILE: 0000A0-0

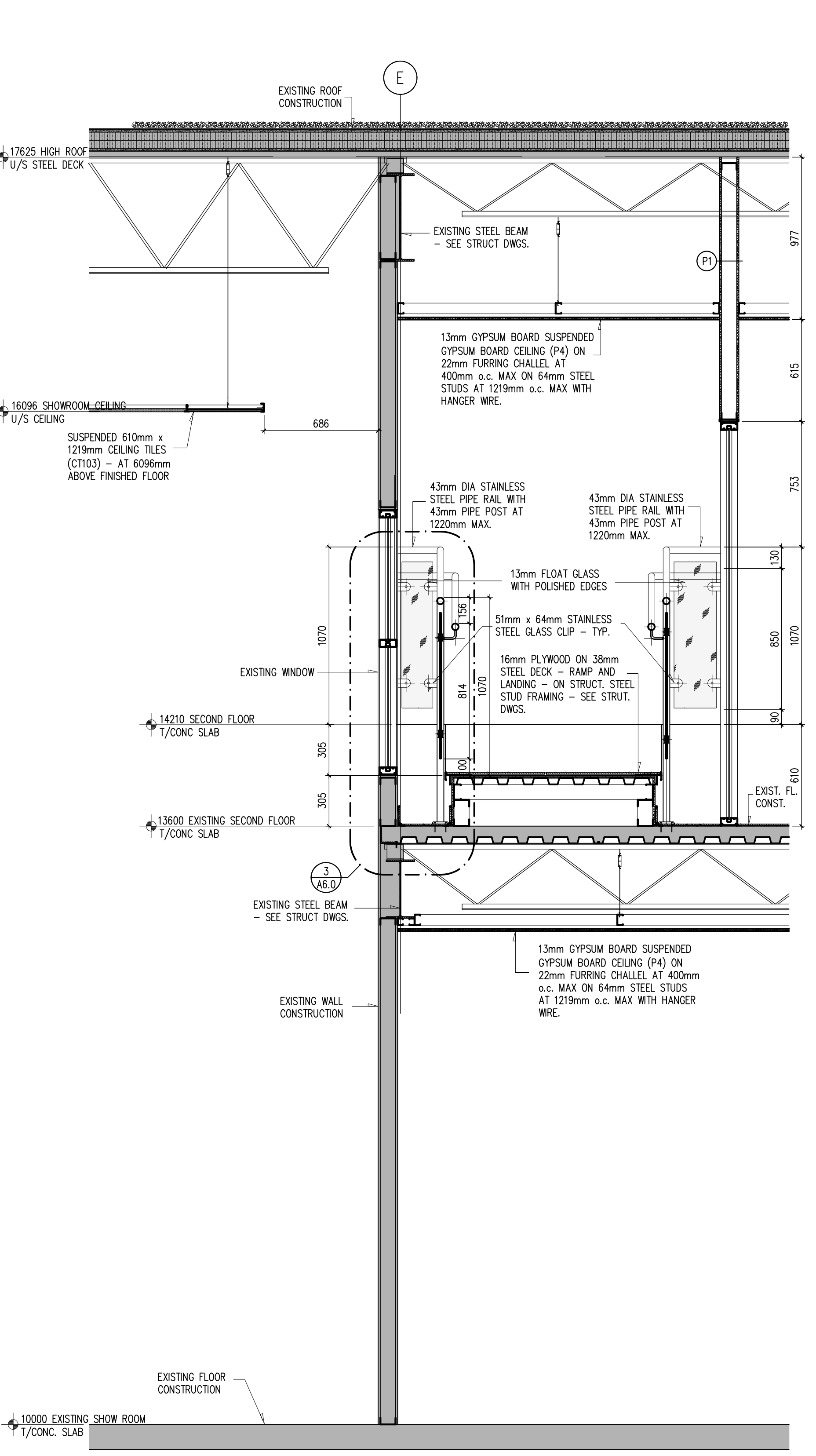

2 SECTION - SECOND FLOOR OFFICE RAMP
A6.0 SCALE: 1:20 CADD FILE: 0000A0-0

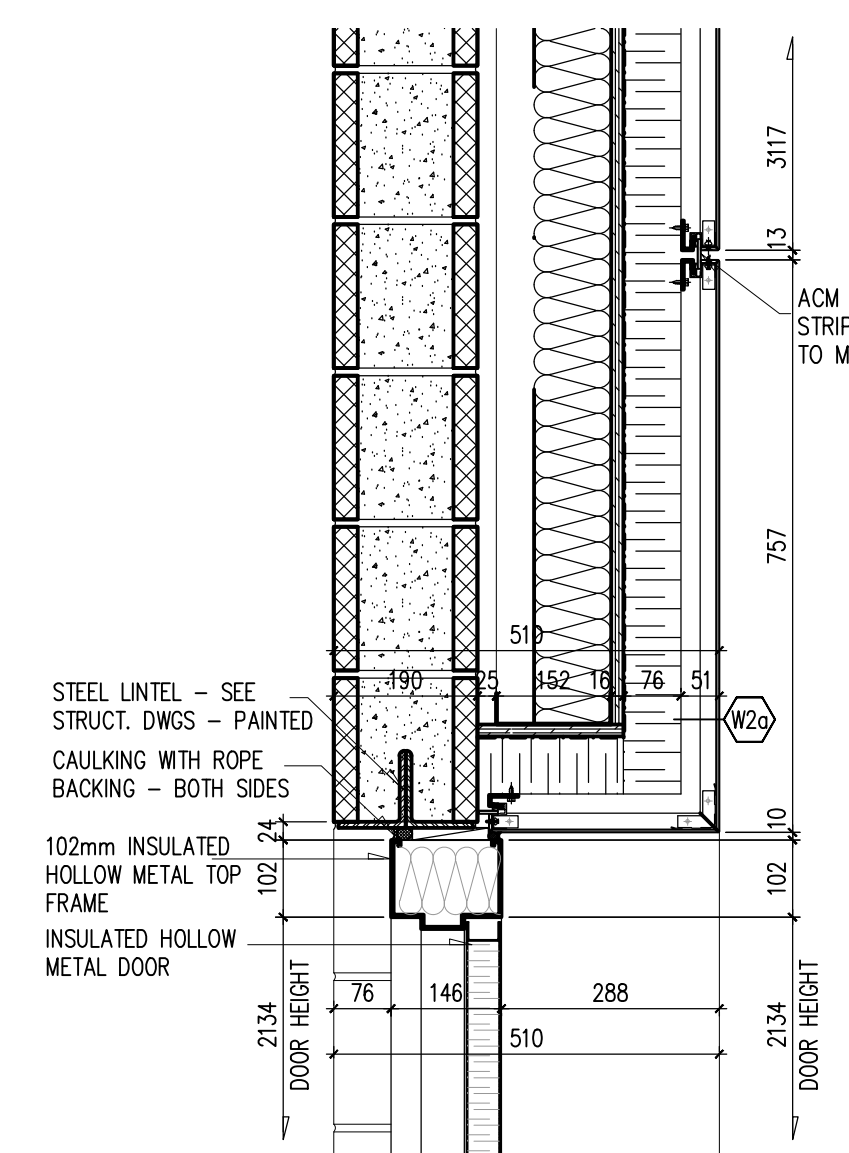

6 DETAIL - HOLLOW METAL DOOR HEAD
A6.0 SCALE: 1:10 CADD FILE: 0000A0-0

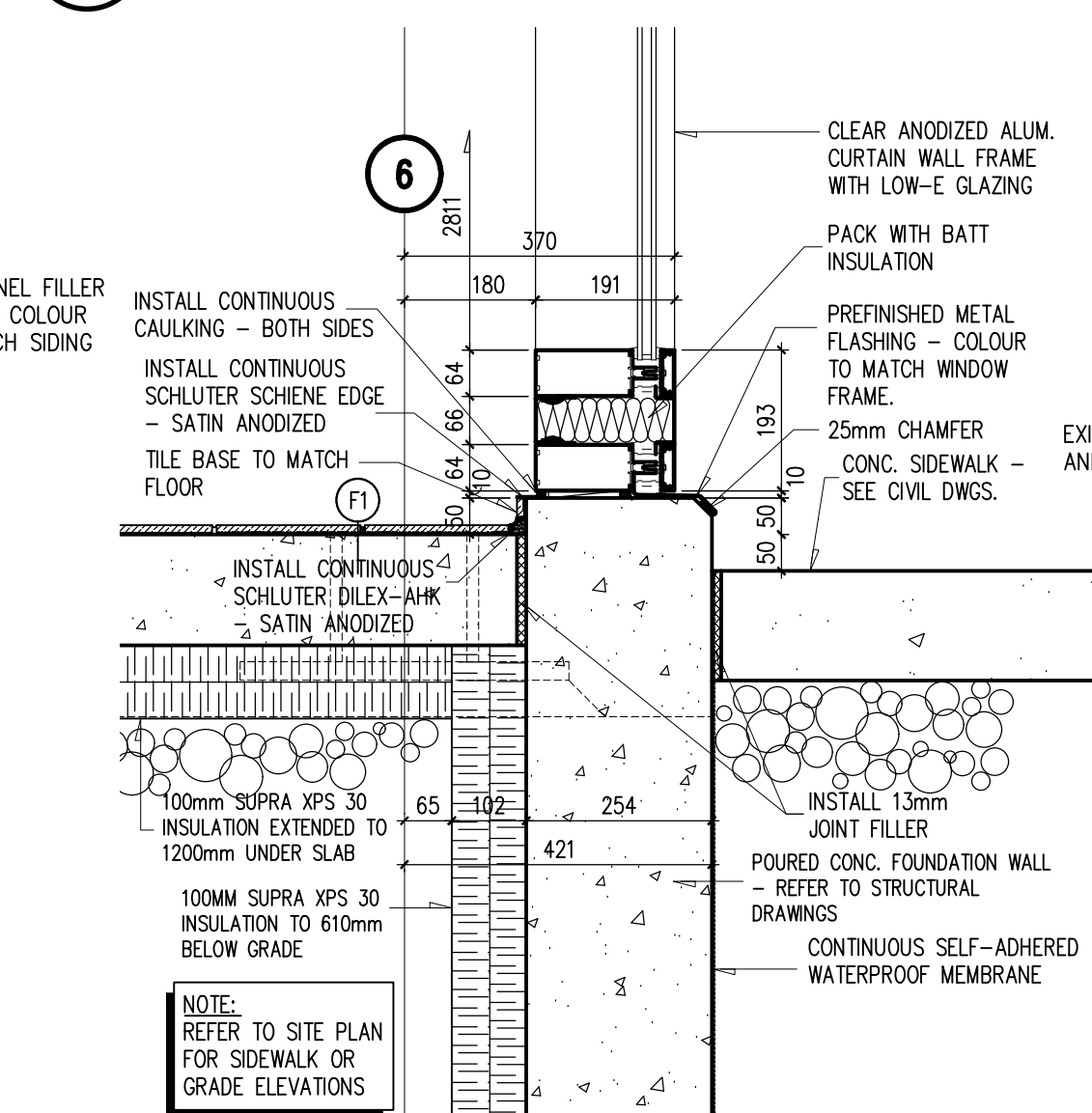

5 DETAIL - WINDOW SILL
A6.0 SCALE: 1:10 CADD FILE: 0000A0-0

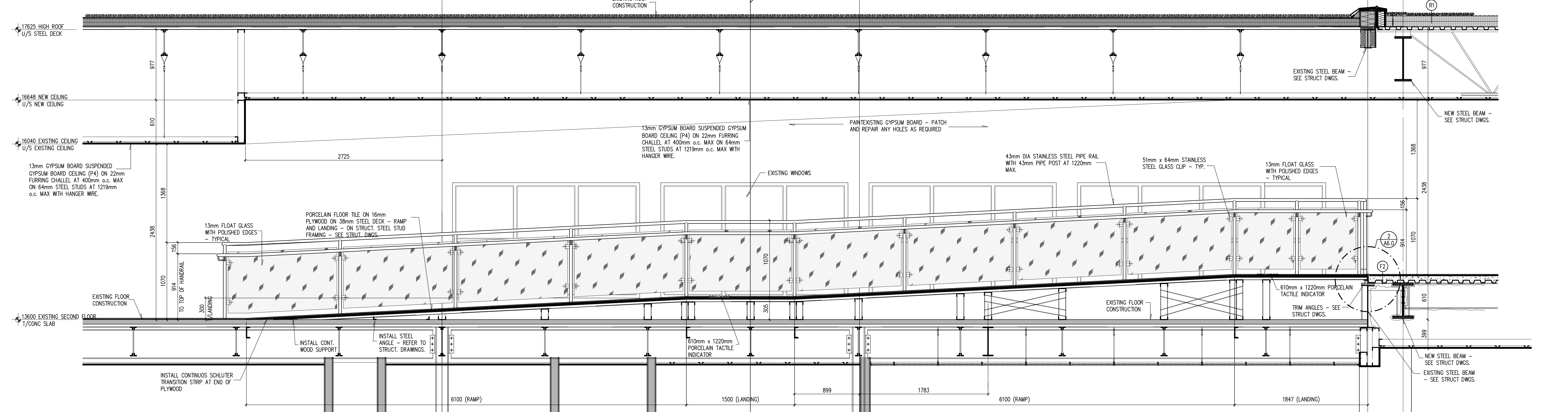

1 SECTION - SECOND FLOOR OFFICE RAMP
A6.0 SCALE: 1:25 CADD FILE: 0000A0-0

DATE	REV.	DESCRIPTION	DRN BY
APR. 1/25	1	ISSUED FOR PRELIMINARY PRICING	SES

REVISION RECORD	
DATE	DESCRIPTION



CONTRACTOR MUST CHECK AND VERIFY ALL DIMENSIONS AND BE RESPONSIBLE FOR SAME. REPORTING ANY DISCREPANCIES BEFORE COMMENCING WORK. LATEST APPROVED DRAWING ONLY TO BE USED FOR CONSTRUCTION. PRINTS ARE NOT TO BE SCALED.

PROJECT	
CLARINGTON TOYOTA	
10 SPICER SQUARE, BOWMANVILLE, ON. L1C 5M2	
DRAWING TITLE	DRAWING No.
MISCELLANEOUS DETAILS	A6.0
SCALE	JOB No.
AS NOTED	30-23
FILE NAME	PLOT DATE
30-23 A4.0	4/14/2025